

NAME Basis Setup (Grip)	DATA 2006-02-09	RACE	TRACK	ROAD SURFACE PATTERN <input checked="" type="checkbox"/> CARPET <input type="checkbox"/> URETHANE · FLOORING · TILE
-----------------------------------	---------------------------	------	-------	--

CHASSIS : STD SP SKELETON SP COLOR
 WHEEL BASE : M L
 ANTENNA : STD SHAPE MEMORY ANTENNA
 BALL BEARING : Yes No

SETTING Fun <input checked="" type="checkbox"/> Grip Drift
BODY Ferrari F430
BATTERY ALKALINE DRY <input checked="" type="checkbox"/> SPEED POWER 90

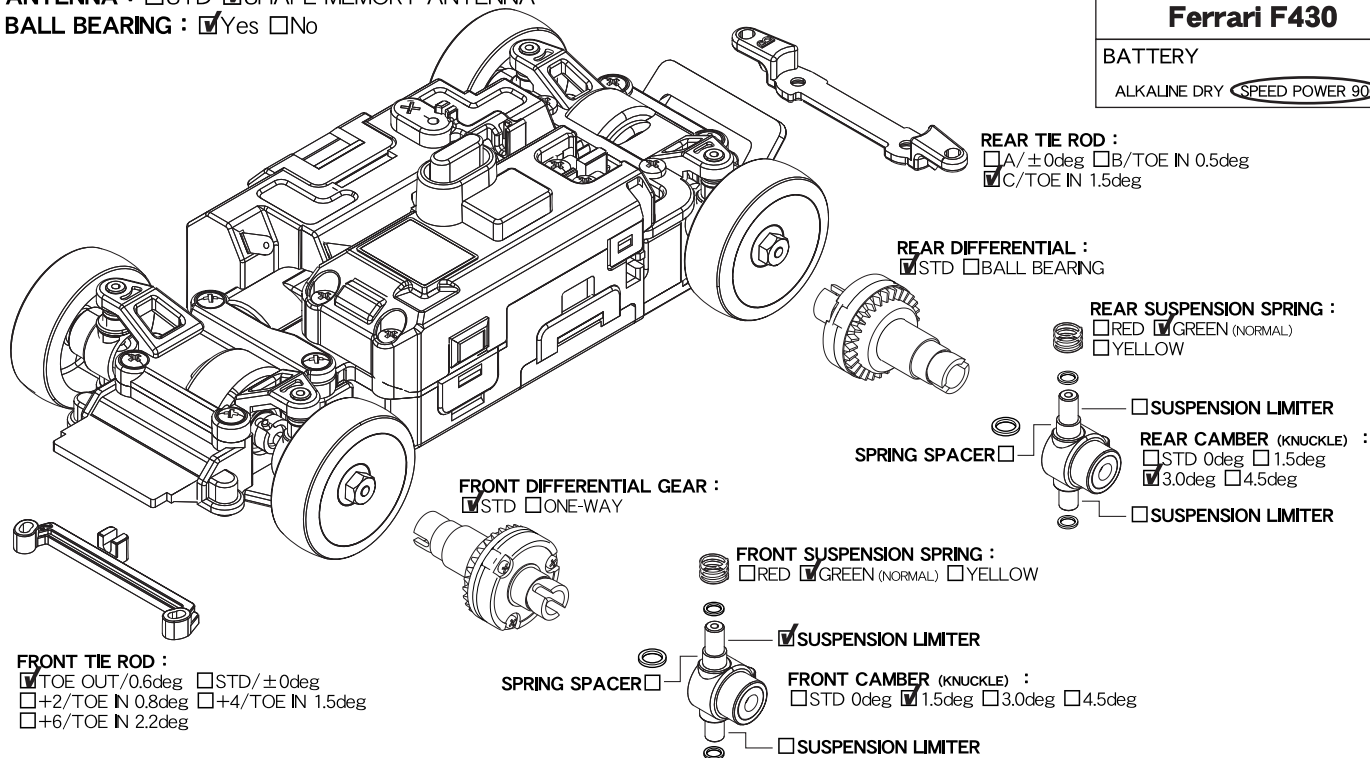

<input checked="" type="checkbox"/> N <input type="checkbox"/> W	FRONT WHEELS	No. MDH100MS	OFF-SET 3.5 mm
<input checked="" type="checkbox"/> N <input type="checkbox"/> W	FRONT TIRE	No. MZW2-30	HARDNESS 30
		PATTERN	<input checked="" type="checkbox"/> NORMAL · <input type="checkbox"/> FLAT

<input type="checkbox"/> N <input checked="" type="checkbox"/> W	REAR WHEELS	品番No. MDH100MS	OFF-SET 1 mm
<input type="checkbox"/> N <input checked="" type="checkbox"/> W	REAR TIRE	No. MZW30-20	HARDNESS 20
		PATTERN	<input checked="" type="checkbox"/> NORMAL · <input type="checkbox"/> FLAT

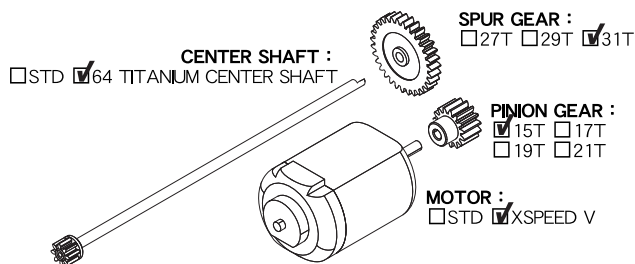

- 装着パーツ :**
- ALUMINUM MOTOR HOLDER SET
 - ALUMINUM MOTOR COVER
 - ALUMINUM REAR TOE CONTROL ROD
 - ALUMINUM FRONT UPPER COVER
 - ALUMINUM REAR UPPER COVER
 - HARD UNIVERSAL SWING SHAFT
 - HARD DIFF. CUP JOINT
 - SP SERVO GEAR SET
 - TITANIUM SCREW SET

OTHERS OPTIONAL PARTS :
